

55" Ultra High Brightness Hanging Double-Sided Displays



Maximise window displays by broadcasting content inwards and outwards, even in direct sunlight

Perfect for Window Displays

With a high definition $3,500\text{cd/m}^2$ outward-facing screen to combat direct sunlight and a 4K resolution $1,000\text{cd/m}^2$ inward-facing screen to combat brightly-lit indoor spaces, these dual-sided displays are designed for shopfront windows. On top of this, they are also ultra resistant to blackening defect up to 110°C .



$3,500\text{cd/m}^2$
Outward Facing Screen

High Definition Resolution (1920x1080px)

$1,000\text{cd/m}^2$
Inward Facing Screen

4K Resolution (3840x2160px)

Lightweight Slim Enclosure

Thanks to their streamlined design, these innovative displays feature a slim depth, minimal cord clutter, and high energy efficiency. Plus, not only is the aluminium enclosure incredibly lightweight for easy installation, it also has high thermal conductivity. This allows rapid heat loss, improving overall performance and increasing lifespan.

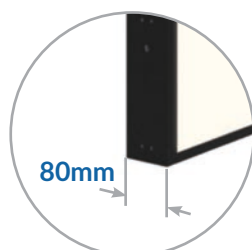

$3,500\text{cd/m}^2$ & $1,000\text{cd/m}^2$ Double-Sided



Integrated Android 14 Media Player



4K Display (Inside Screen only)



Freestanding Version Available



Smart Temperature Control



Plug and Play



Network Upgrade



24/7 Commercial Use



3-Year Warranty



Lifetime Tech Support

Other Features

Ultra Resistant to Blackening Defect

Thanks to their special ultra-high brightness panels, these displays can withstand surface temperatures up to 110°C without suffering from any blackening defect. This is crucial for outward-facing window displays, which must contend with exposure to direct sunlight.



Different Content on Each Side

When using our user-friendly online CMS software, you can really capitalise on the duality of these displays by broadcasting different content on each side. Tailor your messaging to people inside and outside the building for maximum effectiveness.



Integrated Ceiling Mount

The integrated ceiling mount comes included at no extra cost, keeping cables hidden for a clean look. Its adjustable height lets you perfectly align the display with your window or viewing area for an ideal presentation.

Included at No Extra Cost!



Freestanding Option Available

For projects where hanging installation is not possible, these versatile displays can also be transformed into a freestanding solution using the optional floor stand. No matter which mounting option you go for, an easy install is guaranteed.



Integrated Android 14 Media Player

The integrated Android 14 media player allows you to easily update on-screen content via USB plug and play. Alternatively, upgrade your screen to be networked without needing any additional hardware to unlock our cloud-based CMS software. Third-party software can be installed instead if required.



Accessible Ports

To prevent tampering, the AV ports are recessed into the top of the enclosure. However, they are still accessible for easy content updates via USB plug and play. This design strikes the perfect balance between user-friendliness and commercial use.



Integrated Speakers

The displays feature two integrated slimline speakers for applications that require an audio element.



24/7 Commercial Use

With commercial grade LCD panels, LED backlights and internal components, these displays have the ability to be in constant use 24/7 for over 70,000 hours. They also have no external buttons or controls to avoid tampering.



Key Features



AMBIENT LIGHT SENSOR



PLUG AND PLAY



3,500CD/M² & 1,000CD/M²
DOUBLE-SIDED



ULTRA RESISTANT TO
BLACKENING DEFECT

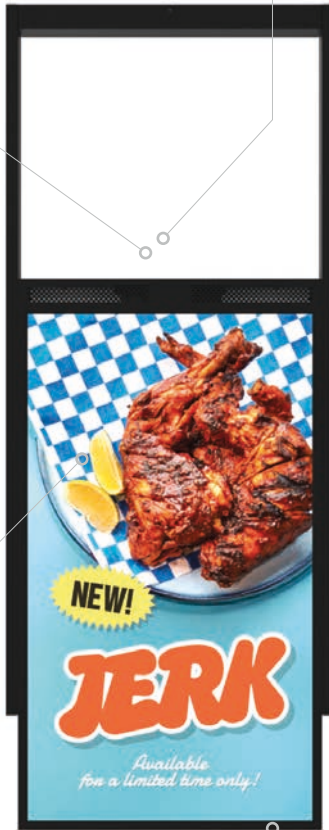

SMART TEMPERATURE CONTROL

LIGHTWEIGHT ALUMINIUM
ENCLOSURE

EASY INSTALL

OPTIONAL NETWORK UPGRADE



3,500cd/m²
Outward Facing Screen

SUNLIGHT READABLE



DIFFERENT CONTENT ON
EACH SIDE

ACCESSIBLE PORTS



FREESTANDING OPTION
AVAILABLE

Specification Table

V.1.1		UDS55UHD10
Display	Side A Resolution [px]	1920 x 1080 @60Hz
	Side B Resolution [px]	3840 x 2160 @60Hz
	Display/Active Area [mm]	1208.6 x 679.4
	Aspect Ratio	16:9
	Side A Brightness [cd/m ²]	3,500
	Side B Brightness [cd/m ²]	1,000
	Colour	16.7M (10-Bit)
	Viewing Angle [°]	89/89/89/89
	Contrast Ratio	1,300:1
	Blackening Defect Free	Up to 110°C (230°F)
	Orientation Support	Portrait
	Operating Hours	24/7 Commercial Use
System & Performance	CPU	RK3568 64bit Cortex-A55 Quad @2GHz
	GPU	Quad Mali-G52 2EE
	Graphics API Support	OpenGL ES 1.1/2.0/3.2, OpenCL 2.0 and Vulkan 1.1
	OS Operating System	Android 14
	RAM	4GB
	Storage	32GB
	Media Format	Supports FHD 60FPS H.264/H.265 video encoding
	LAN	10/100/1000M RJ45
	Wi-Fi	Dual-band 2.4GHz / 5GHz (802.11a/b/g/n/ac)
	Bluetooth	5.0
Connectivity & Interface	HDMI	1 x HDMI 2.0 IN
	USB	1 x USB 3.0 Type-A; 3 x USB 2.0 Type-A; 1 x USB Type-C (OTG only)
	RS232	1 x RJ45 (Serial Control)
	Ethernet	1 x RJ45 (10/100/1000M)
	Audio Out	1 x 3.5mm Audio Out
	Expansion Slot	1 x Micro SD
	Power Input	1 x IEC C13 (Kettle Lead)
	Switch	1 x Power Switch
	Speakers	5W x 2
	Power Management	Power Supply
Power Consumption		Typical: tbc; Max: 390W
Standby Power		≤0.5W
Dimensions & Weight	Screen Only Dimensions (mm)	727 x 1317.2 x 80
	Hanging Display Dimensions (mm)	786 x 1725 x 80 or 786 x 1975 x 80
	Package Dimensions (mm)	906 x 1474.7 x 255
	Net Weight [kg]	40
	Gross Weight [kg]	45
Environmental Conditions	Operating Temperature [°C]	0 to 40°C
	Storage Temperature [°C]	-10°C to 55°C
	Operating Relative-Humidity [%]	10% to 80%
	Storage Relative-Humidity [%]	10% to 80%
Accessories	Included Accessories	Kettle Power Lead, Remote Control + Batteries; User Manual (QR Code x2); Quick Start Guide
	Optional Accessories	Floor Stand Mount, Network Upgrade
Warranty	Warranty Period	3 Years
	Technical Support	Lifetime

Technical Drawing

Screen Only

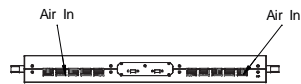
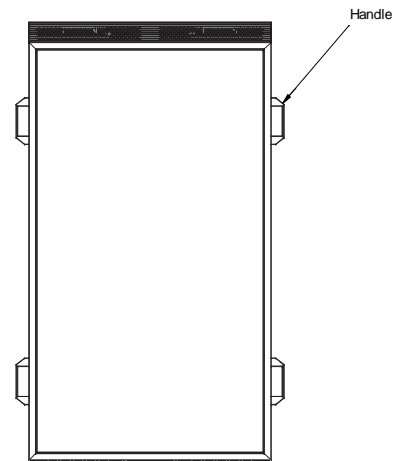
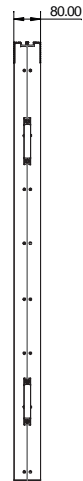
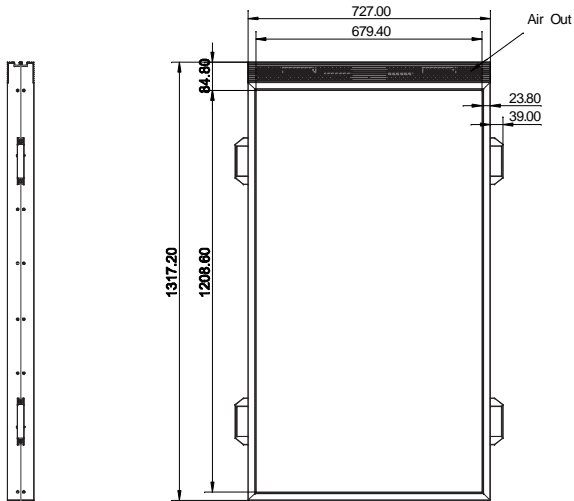
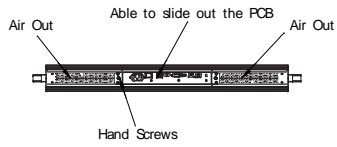

Screen and Hanging Mount

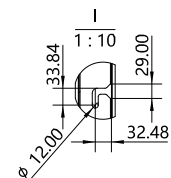
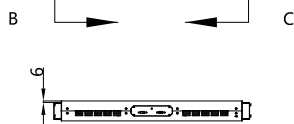
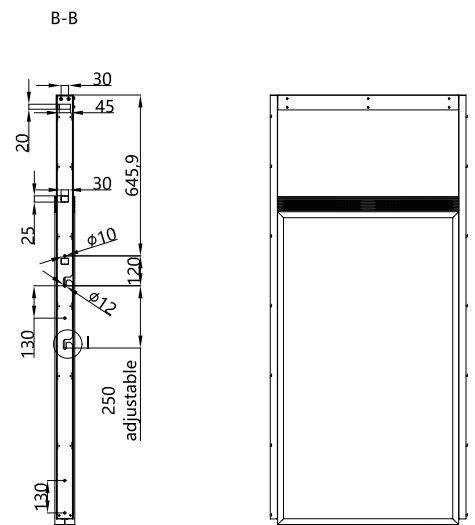
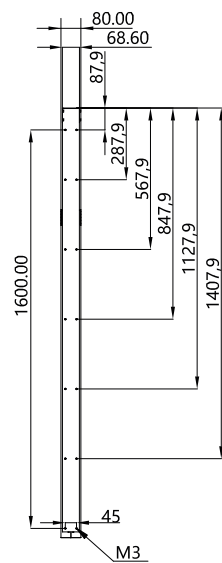
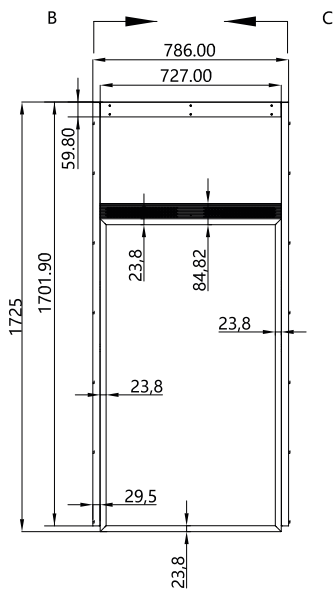
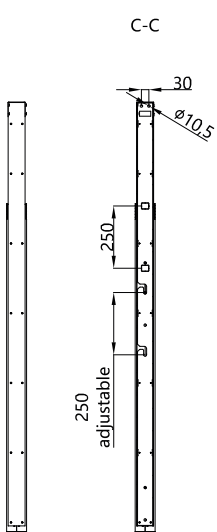
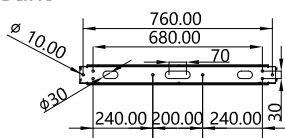

Why Choose Our Commercial Display Solutions?



Lifetime Technical Support

From the moment you receive your product, throughout the duration of your warranty and even after your warranty has expired we are here to support you. If you require any assistance setting up or using your product, or have any problems at all, we can provide free technical support via telephone and email.

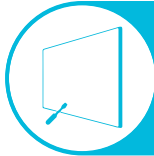

On-site Support and Maintenance*

If needed, we can provide an installation service for any of our products. We can also set up service-level agreements for larger projects that require maintenance contracts.



Extended Warranty*

All of our commercial display products come with a 3 year commercial warranty as standard but if you want to extend this you can upgrade this to cover a 5 year period at point of purchase.



Training

As well as providing free remote CMS training sessions and webinars we can also visit you to deliver bespoke training for our software and hardware*.



Advanced Replacements†

Should your display suffer from any kind of hardware failure during the warranty period we will send you an advanced replacement and arrange for your old display to be collected, free of charge. This ensures no downtime where you are without a screen.



Custom Product Testing & Configuration

If you need us to test third party software or a website, or configure your screen in a particular way before it is dispatched (e.g. in a particular orientation or network mode), we can do so to make your life easier.



3D Rendering

Want to know how a particular screen will look once installed? Send us a photo of the location and we will create a 3D rendering of any screen in situ to help you to visualise how amazing it will look.



Logistics Support

We hold more stock in our UK warehouse than any other manufacturer so we can help you meet tight deadlines. For last minute orders we can also offer special express or morning delivery options*. We also carry out UK based quality control checks on every display before it leaves our warehouse.



Project Support

If you need to loan a sample unit to test we'd be more than happy to arrange this. We can also provide a rental service for temporary projects*.



Customisation*

Your display can be customised to suit your requirements by adding your logo or printed graphics or even tailoring the colour of a display. We can also carry out hardware modifications to existing products or manufacture bespoke solutions for special projects.



Extras*

As well as being able to provide accessories and add-ons, such as extra remote controls, NUC PCs and video wall controllers, we can also supply custom made flight cases which are great if a display needs to be moved safely from place to place.

†UK mainland only

*These particular services may incur additional charges